



**Beverage Air**<sup>®</sup>

**IMPORTANT  
INFORMATION**

FOR

**MM and HB SERIES**

MMR/MMF/HBR/HBF/MMRF/HBRF

This cooler has passed the  
**QUALITY CONTROL INSPECTION**  
And meets the high standards at Beverage-Air  
This inspection includes complete refrigeration  
system, cabinet construction & finish.

IMPORTANT  
PLEASE RETAIN FOR YOUR RECORDS

**SALES OFFICE: 3779 CHAMPION BLVD., WINSTON - SALEM, S.C. 27105**

**PHONE: (336) 245-6400 TOLL FREE 1-800-845-9800**

**TECHNICAL SERVICE: 1-800-684-1199**

**PARTS ORDER FAX: 1-800-262-9381**

**CORPORATE OFFICE: WINSTON-SALEM, NC**

**MANUFACTURING FACILITY: BROOKVILLE, PA.**



# Beverage-Air®

## INSTALLATION AND OPERATING INSTRUCTIONS

### 1. INSTALLATION

a. Receiving Inspection: Upon receipt, check all packages for accessories or optional components, including legs, caster, shelves or pan slides. Keys for door locks are attached to one of the doors. (When lock is installed.)

b. Legs & Casters: Each cabinet is provided with four threaded legs or casters shipped separately (in some models only). Legs and casters screw directly into the weld nut provided in each corner of the base. Please note casters and leg are not included in all models and are optional.

c. Leveling: To provide adequate drainage and proper door alignment and operation, it is necessary that the cabinet be level. Level cabinet from front to rear and from side to side by adjusting leg inserts. This should be done after cabinet has been set in its final operating position.

d. Shelves: Included are three epoxy coated wire shelves per door opening (5 per door in MM series and 3 per door in HB series). Shelf spacing is adjustable with enclosed shelf supports to suit requirements. (Figure 1.)

e. Locating Cooler: For proper operation of the cooler, provide at least three inches of space between the rear of the cabinet and any adjacent wall or fixture and minimum of 12 inches of clearance between the top of the cooler and the ceiling or any other fixture.

### 2. OPERATION

a. Electrical Supply & Connections: A wiring diagram is provided with this manual. It is important that the cabinet be connected into a separate single circuit. Before connecting cabinet, check line voltage to assure it is compatible with the voltage specified on the data plate. (See Fig. #4). Low line voltage is often the cause of service complaints. Wiring should be sufficient to carry the electrical load and to meet local codes. A qualified electrician should make the necessary electrical connections. Be sure cabinet is properly grounded. Check supply voltage after unit has started to be sure circuit is not overloaded.

208/230V Field Wired Unit: Cabinet must be connected to a 208/230V/60Hz grounded supply. Prior to connecting power, ensure voltage between any supply conductor and neutral is 115V. Failure to properly wire unit will void all warranties and may result in property damage.

#### Dual Temp Models

Dual temp models come with two separate systems, a system for each section. Each system has to be connected into a separate a dedicated circuit. Ensure the circuits are rated for amperage draw stated on the data plate.

#### Use of Extension Cords:

**NEVER USE EXTENTION CORDS. BEVERAGE AIR WILL NOT WARRANTY ANY FREEZERS AND REFRIGERATORS THAT HAVE BEEN CONNECTED TO AN EXTENSION CORD.**

b. Initial Start-Up: Turn power on and check to verify that the compressor and condenser fan are running. On freezers, evaporator fans are delayed at start up until the evaporator has pulled down to a predetermined temperature. Once the fans are running, a switch behind each door will stop the fans while the door is open.

c. Interior Lights: In the solid door models, interior lights are actuated by a door switch. Glass door units have a light switch inside the cabinet.

#### d. Temperature Control, Defrost System and Condensate Disposal:

All H series are equipped with an electronic control. This control is located on right hand side of the cabinet above the door. The control has four buttons as shown in the picture below.

Freezers are shipped from the factory with control set at -3 °F and refrigerators are shipped with control set 34 °F. To change the temp control setting, press and hold the Set button for 3 seconds. The set value will be displayed and °F will start blinking. Use the Up and Down arrow buttons to change the set point. Push the Set button again to exit.

Freezers are provided with an electric defrost heater actuated by the electronic control. The controls initiates a defrost cycle every 8 hours. For efficient operation, the defrost cycle is temperature and time terminated. Defrost can be manually initiated by pressing and holding the Defrost button for 3 seconds or longer. The control displays dF during the defrost cycle.

Refrigerators do not have a defrost cycle. However, defrosting occurs automatically with each cycle of the compressor. All cabinets are equipped with an automatic overhead condensate disposal system. No outside drain hook up is necessary.



### 3. MAINTENANCE

a. Cleaning Cabinet Exterior: Cabinets should be cleaned with a solution of mild soap and water. Do not use caustic soap or abrasive cleaners, since these might damage the cabinet finish. If stainless steel surfaces become discolored, scrub by rubbing only in direction of the finish grain. The anodized aluminum interior and exterior should be cleaned with mild soap and water. Do not use steel wool.

b. Cleaning Interior Surfaces: The inside of the cabinet is coated with baked-on vinyl or stainless steel. To clean, use mild soapy water and cloth, or sponge.

c. Condenser: For efficient operation, it is recommended that the condenser coil and fans be cleaned every 4 to 6 months. Remove grille for access. Vacuum clean front surface of coil thoroughly or direct forced air through condenser from the rear. If necessary, use a stiff bristled brush to loosen dirt.

d. Condensate Evaporation Pan: The condensate evaporation pan (See Fig. 4) must be cleaned periodically to prevent foul odors and to operate efficiently. Vacuum clean if dry or sponge clean with soapy water.

### 4. SERVICING

All Beverage-Air products are inspected and performance tested at the factory before crating to insure years of satisfactory operation. However, in time minor servicing will be necessary to maintain or restore peak performance of the cabinet in particular applications. Problems usually encountered and their corrections are as follows:

#### **Problem: High temperature.**

Correction: **(1)** Inside air duct might be blocked with product. Be sure space between shelves, in center of cabinet, is open for proper air circulation. **(2)** Very high usage, or door left open, can raise temperature. Give cabinet time to pull back down. **(3)** Cabinet might be in defrost cycle; check timer box for position of cam. **(4)** Condenser could be clogged with dirt, cutting down air flow. Check and clean, if dirty.

#### **Problem: Doors will not close properly.**

Correction: **(1)** Door hinges, particularly on bottom, can get dry and caked with dirt, Etc. Clean, if needed, and lubricate wear surfaces lightly. **(2)** If cabinet has been moved, it might not be level. Re-level if needed.

In case additional service is required, a qualified service agency or the factory should be contacted. When calling for service at the factory, be prepared to give serial and model numbers of the cabinet to insure prompt attention.

# SHELF CLIP INSTALLATION

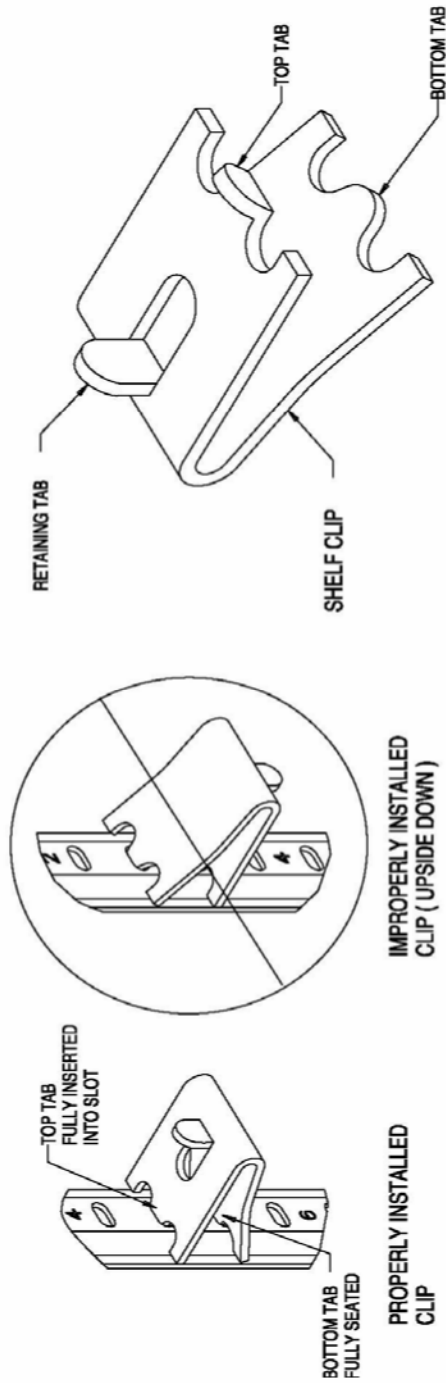

- INSTALLATION INSTRUCTIONS**
- 1) DETERMINE PROPER LOCATION FOR SHELF CLIPS. THE REFERENCE NUMBERS ON THE PILASTER CAN SERVE AS A GUIDE TO ENSURE ALL CLIPS ARE PROPERLY LOCATED.
  - 2) INSERT TOP TAB OF THE SHELF CLIP INTO THE DESIRED HOLE OF THE PILASTER. THE RETAINING TAB SHOULD BE FACING UPWARDS AS SHOWN.
  - 3) ROTATE THE CLIP DOWNWARDS AND INSERT THE BOTTOM TAB INTO THE APPROPRIATE HOLE ON THE PILASTER. THE CLIP MAY NEED TO BE SQUEEZED SLIGHTLY DURING INSTALLATION.
  - 4) INSTALL ALL REMAINING CLIPS AS DESCRIBED ABOVE.
  - 5) INSTALL SHELVES ONTO CLIPS WITH THE PRODUCT RETENTION BAR FACING UPWARD. BE CAREFUL NOT TO DISLODGE CLIPS DURING SHELF INSTALLATION.
  - 6) SHELVES MUST BE PLACED SUCH THAT THE RETAINING TAB ON THE SHELF CLIP CAPTURES THE SHELF AS SHOWN.
  - 7) PRIOR TO LOADING THE SHELF, ENSURE THAT THE SHELF IS RESTING ON EACH OF 4 CLIPS AND THE CLIPS ARE INSTALLED AS SHOWN.

**WARNING**

- IMPROPER SHELF CLIP INSTALLATION MAY CAUSE SHELF AND/OR PRODUCT TO FALL RESULTING IN DAMAGE TO THE UNIT AND BODILY INJURY.
- DO NOT OVERLOAD THE SHELVES. THE UNIT IS DESIGNED TO UTILIZE ALL SHELVES THAT ARE SUPPLIED IN AN EQUALLY SPACED MANNER. IF LESS SHELVES OR A DIFFERENT CONFIGURATION IS DESIRED, CONTACT THE MANUFACTURER TO ENSURE SHELF OVERLOADING WILL NOT OCCUR.

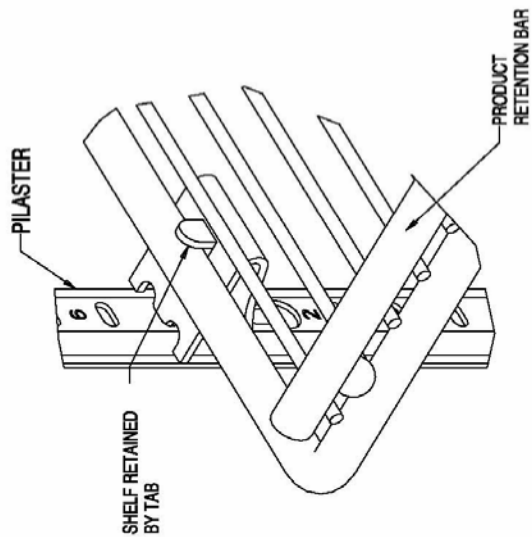

Figure 1

# Bi-pin Florescent Lamp Installation / Verification

(Glass Door Models Only)

a: Visual verification can be made on units without safety shields by using the identification mark on the end of the bulb. Properly installed bulbs will have the mark centered between the halves of the lamp holder. (See Pictures 1 and 2 below)

b: On units with shields, the identification mark cannot be seen. Physically verify that the lamp has been rotated and locked into place. (See pictures 3 and 4 below)

c: Prior to applying power to the unit, verify that all lamps are properly installed and fully engaged in the lamp holders. Proper lamp engagement is achieved by rotating the lamp 90 degree from its insertion position until it snaps or clicks into below.

**Caution: Improperly installed lamps may cause damage to the lighting circuit.**

Beverage-Air shall have no liability whatsoever for equipment or component failures or other damages or losses which arise as a result of improper installation of lamps.

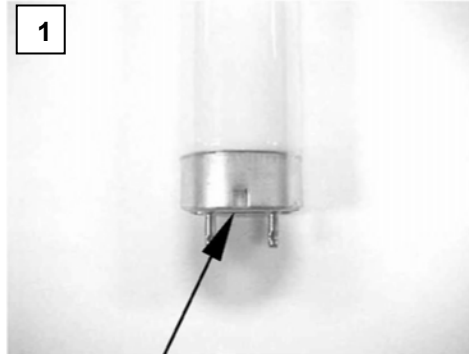

1

Bi-pin lamp end identification mark

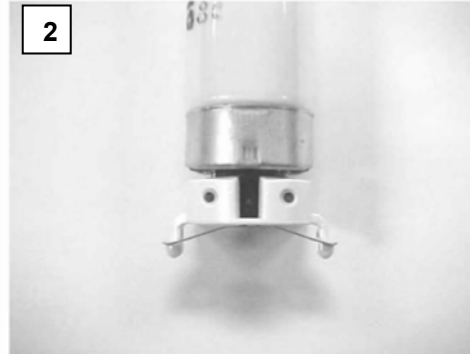

2

Bi-pin lamp end properly installed into shield (Note location of identification mark)

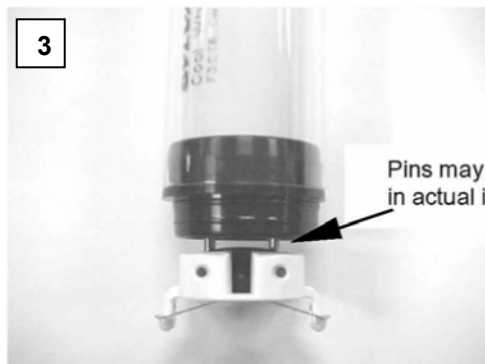

3

Properly installed lamp with shield. Requires physical verification that lamp has been rotated and locked into place

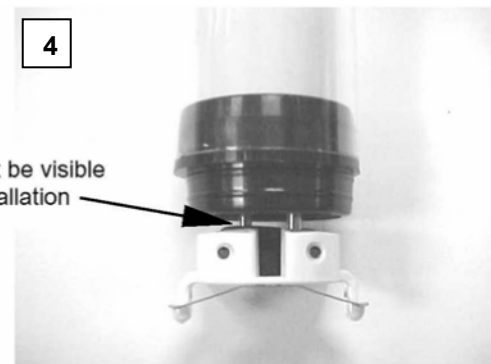

4

Improperly installed lamp with shield. Note that pins have not achieved full 90 degree rotation

Pins may not be visible in actual installation

