



# BEVERAGE-AIR

Project: \_\_\_\_\_

AIA#

Item: \_\_\_\_\_

Location: \_\_\_\_\_

SIS#

Approved: \_\_\_\_\_

## WTRD REFRIGERATORS WITH DRAWERS

### WTRD72AHC Four Drawer Worktop Refrigerators

### Hydrocarbon Series

MODELS:

WTRD72AHC-4

WTRD72AHC-4 Refrigerators With Drawers: Worktop Series

**3 Year Parts/Labor Warranty**  
**Additional 2 Year Compressor Warranty**

### CABINET CONSTRUCTION



WTRD72AHC-4

- Stainless steel front, sides, door and drawers (*galvanized back & bottom*)
- Interior liner is made of corrosion resistant aluminum
- Stainless steel worktop for added durability
- Full electronic control
- Interior thermometer is standard
- 4" Removable backsplash for flexibility and ease of cleaning
- Two (2) epoxy coated shelves
- Painted aluminum door and drawer handles
- Snap-in door and drawer gaskets
- Upper and lower pull-out drawers accommodate 6" deep pans
- Stainless steel drawer frames supported on telescoping drawer slides
- Drawer slides include locking mechanism that prevents drawer from being inadvertently pulled off cabinet
- 6" Casters, (2) with brakes standard
- Maintains product temperature between 36°F and 38°F

### OPTIONS & ACCESSORIES

- Stainless steel back and grille
- Stainless steel interior
- Right or left hinged door
- Locks (solid doors only)
- Wire shelf divider
- Cutting board
- 3" Casters or 6" legs
- Low profile casters
- Remote option

### REFRIGERATION SYSTEM

- Refrigeration system uses R290 refrigerant to comply with all environmental concerns
- Automatic, non-electric defrost
- Epoxy coated evaporator coil



3779 Champion Blvd., Winston-Salem, NC 27105  
1-888-845-9800 Fax: 1-336-245-6453  
Beverage-Air.com sales@bevair.com



# BEVERAGE-AIR

## Worktop Refrigerators – With Drawers Models: WTRD72AHC-4 Removable Backsplash

MODEL	WTRD72AHC-4
<b>EXTERNAL DIMENSIONAL DATA</b>	
Width Overall	72"
Depth Overall	32"
Height Overall with 6" Casters	39 5/8"
Number of Doors	1
Depth with Door Open 90 °	52 1/4"
Drawer Opening (inches)	(4) 19 1/2" x 9 3/8"
Number of Drawers	4
<b>INTERNAL DIMENSIONAL DATA</b>	
NET Capacity (cubic ft.)	17.88
Internal Width Overall (in)	68"
Internal Depth Useable (in)	15 3/8"
Internal Height Overall (in)	23"
Number of Shelves	2
<b>ELECTRICAL DATA</b>	
Full Load Amperes 115/60/1	3.0
<b>REFRIGERATION DATA</b>	
Horsepower	1/5
Capacity (BTU/Hr)*	1350
<b>WEIGHT DATA</b>	
Gross Weight (Crated lbs)	370 lbs
Height - Crated	35"
Width - Crated	74"
Depth - Crated	33"

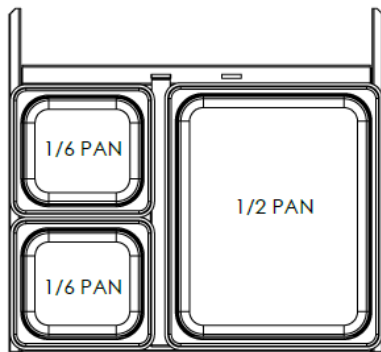

### Model Views

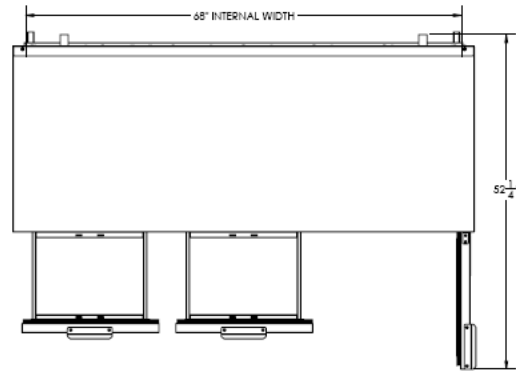

Plan View

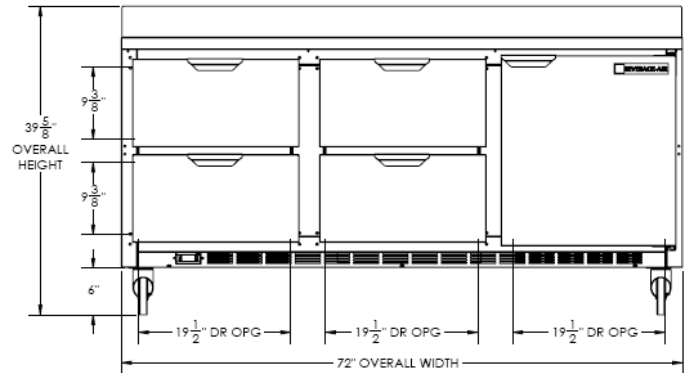

Elevation View

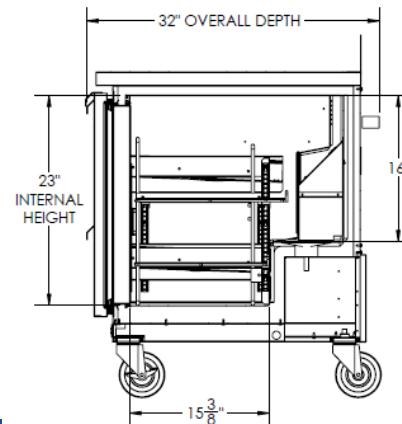

Side View

### ELECTRICAL CONNECTION



115/60/1  
NEMA-5-15P

Units pre-wired at factory and include 8' long cord and plug set.



an Ali Group Company



The Spirit of Excellence

3779 Champion Blvd., Winston-Salem, NC 27105  
1-888-845-9800 Fax: 1-336-245-6453  
Beverage-Air.com sales@bevair.com