



BEVERAGE-AIR

Project: _____	AIA#
Item: _____	SIS#
Location: _____	
Approved: _____	

MT10™ MERCHANDISER: HINGED DOOR MODEL

MARKETEER™ MERCHANDISERS

MT10 White Hinged Door Model
Hydrocarbon Series

MODEL:
MT10-1W



3 Year Parts / Labor Warranty
Additional 4 Year Compressor Warranty

CABINET CONSTRUCTION

- Standard cabinet exterior finish is heavy duty steel with a white baked on durable coating
- Heavy duty interior construction includes white coated steel
- Mechanical temperature control
- Modern one piece grill
- Double pane lowE argon filled glass door feature outside pane that is tempered for added safety
- Door lock standard
- Self-closing hinged glass door features, pocket door handle
- LED lighting
- Three (3) epoxy coated shelves standard
- Leveling feet

OPTIONS & ACCESSORIES

- Extra shelves and clips
- 3" Casters
- Visislide shelving kit

REFRIGERATION SYSTEM

- Uses environmentally friendly, energy efficient R600 refrigerant, and meets all regulatory requirements for CARB, SNAP, DOE & more
- Condenser is designed to be low maintenance, and energy efficient
- Automatic, non-electric defrost
- Epoxy coated evaporator coil



Please verify qualifying units by visiting:
www.energystar.gov/cfs

3779 Champion Blvd., Winston-Salem, NC 27105
1-888-845-9800 Fax: 1-336-245-6453
Beverage-Air.com Sales@bevair.com



BEVERAGE-AIR.

MODEL	MT10-1W
EXTERNAL DIMENSIONAL DATA	
Width Overall	24 7/8"
Depth Overall	22 13/16"
Height Overall	54 3/8"
Number of Doors	1
Depth with Door Open 90°	46"
Clear Door Opening (in)	21" X 39 7/16"
INTERNAL DIMENSIONAL DATA	
NET Capacity (cubic ft.)	9.43
Capacity 20 oz	126
Internal Width Overall (in)	22"
Internal Depth Overall (in)	16 1/4"
Internal Height Overall (in)	40 5/8"
Internal Height Useable (in)	37 3/16"
Number of Shelves	3
ELECTRICAL DATA	
Full Load Amperes 115/60/1	3.2
REFRIGERATION DATA	
Horsepower	1/6
Energy Consumption	1.740 kWh/day
WEIGHT DATA	
Gross Weight	206 lbs
Height - Crated	65"
Width - Crated	28"
Depth - Crated	27"

Glass Hinged Door Model Model: MT10-1W

Model Views

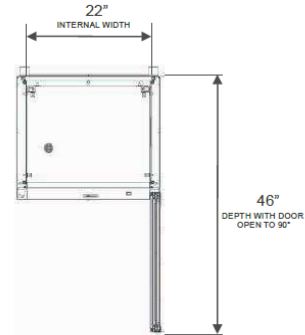

PLAN VIEW

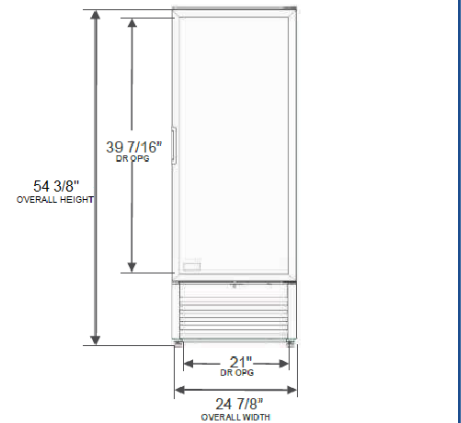

ELEVATION VIEW

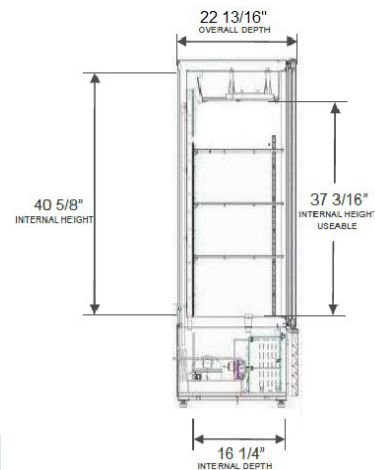

SIDE VIEW

*ELECTRICAL CONNECTION



Unit pre-wired at factory and include 8' long cord and plug set.

115/60/1
NEMA 5-15P



3779 Champion Blvd., Winston-Salem, NC 27105 1-888-845-9800 Fax: 1-336-245-6453 Beverage-Air.com Sales@bevair.com

an Ali Group Company



The Spirit of Excellence