



BEVERAGE-AIR

Project: _____	AIA#
Item: _____	
Location: _____	SIS#
Approved: _____	

MARKETMAX® DUAL TEMP BOTTOM MOUNT WINE REFRIGERATOR

MODEL:
MMRR49HC-1-A-BW-WINE

MMRR49HC Hinged Double Glass Door
Hydrocarbon Series

MMRR49HC Dual Temp Bottom Mount Wine Refrigerator



3 Year Parts/Labor Warranty
Additional 4 Year Compressor Warranty

CABINET CONSTRUCTION

- Exterior finish is heavy duty steel with a black baked on durable coating
- Heavy-duty interior construction includes white coated steel walls
- Modern one-piece grille
- Full electronic control
- Dual temp refrigerator/refrigerator units provide two different operating temperature zones for different types of products
- Double pane lowE argon filled glass doors
- Self-closing door with 120° stay-open feature
- Snap-in gaskets, easy to remove for cleaning or replacement
- Door locks
- LED lighting
- Five (5) white heavy-duty epoxy coated wire shelves
- Four (4) shelf clips included per shelf
- Self-contained bottom mount refrigeration system
- Leveling feet standard

OPTIONS & ACCESSORIES

- Stainless steel or white exterior option
- Black or stainless steel interior option
- Wine rack upgrades: flat and curved (see page 3 for options)
- Additional shelves
- Stainless steel shelf clips
- White and red wine specific controllers 35°F-62°F (see page 3 for options)
- 3" or 6" Casters
- 6" Legs or seismic/flanged legs
- Electronic door lock (Must be ordered at time of unit order)
- Custom wine signage (see page 3 for options)
- Left and right hand door swing (at time of order)
- Remote option* (see note on back page)

REFRIGERATION SYSTEM

- Uses environmentally friendly, energy efficient R290 refrigerant, and meets all regulatory requirements for CARB, SNAP, DOE & more
- Adaptive Defrost
- Epoxy coated evaporator coil
- Maintains product temperatures between 35°F to 62°F



Please verify qualifying units by visiting:
www.energystar.gov/cfs

3779 Champion Blvd., Winston-Salem, NC 27105
1-888-845-9800 Fax: 1-336-245-6453
Beverage-Air.com Sales@bevair.com



BEVERAGE-AIR

Dual Temperature Bottom Mount Reach-In Glass Door Wine Refrigerator Model: MMRR49HC-1-A-BW-WINE

MODEL	MMRR49HC-1-A-BW-WINE
EXTERNAL DIMENSIONAL DATA	
Width Overall	52"
Depth Overall (with handle)	33 5/8"
Height Overall	78 1/8"
Number of Doors	2
Depth with Door Open 90°	56 1/8"
Door Openings (in)	22 3/4" x 52 5/8"
INTERNAL DIMENSIONAL DATA	
NET Capacity (cubic ft.) Refrigerator/Refrigerator	R 21.01 - R 21.01
Internal Width Overall (in)	R 23" - R 23"
Internal Depth Overall (in)	27"
Internal Height Usable (in)	53"
ELECTRICAL DATA	
Full Load Amperes* Refrigerator/Refrigerator	R 2.4 - R 2.4
REFRIGERATION DATA	
Horsepower Refrigerator/Refrigerator	R 1/4 - R 1/4
Capacity (BTU/Hr)* Refrigerator/Refrigerator	R 2317 - R 2317
SHIPPING DATA	
Gross Weight (crated lbs)	700 lbs
Height - Crated	85"
Width - Crated	36"
Depth - Crated	56"

*NOTE: Remote units are field wired and come with 6" legs.
Refrigerant must be specified at time of order.

Model Views

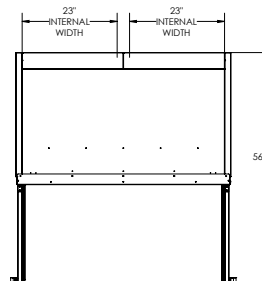

PLAN VIEW

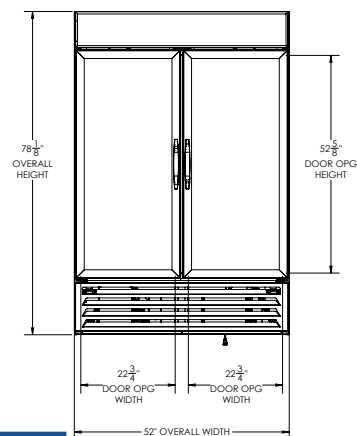

ELEVATION VIEW

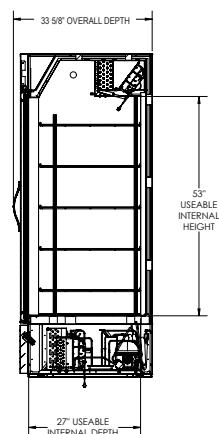

SIDE VIEW

*ELECTRICAL CONNECTION



115/60/1
(2) NEMA 5-15P Units pre-wired at factory and include 8' long cord and plug set.



3779 Champion Blvd., Winston-Salem, NC 27105 1-888-845-9800 Fax: 1-336-245-6453 Beverage-Air.com Sales@bevair.com

an Ali Group Company



The Spirit of Excellence



BEVERAGE-AIR

WINE OPTION UPGRADES

SIGNAGE

Two wine header panels to choose from to call attention to the wine selection



SHELVING

We offer curved and flat wine racks, designed to secure the bottles while keeping them prominently on display. Available in white, black, and chrome finish.

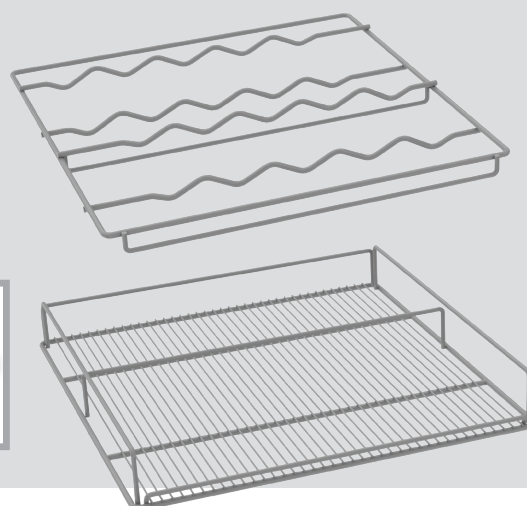

CONTROLLER

White and Red wine specific controllers available. Easily programmed to keep unit and its contents at the necessary set point (between 35-62° F)



