



BEVERAGE-AIR.

Project: _____	AIA#
Item: _____	
Location: _____	SIS#
Approved: _____	

BDC-HC DIPPING CABINET FREEZER

DIPPING CABINET FREEZER
 BDC-HC Dipping Cabinet 12-Flavors
 Hydrocarbon Series

**MODEL:
BDC-HC-12**



**7 Year Parts/Labor Warranty
7 Year Compressor Warranty**

CABINET CONSTRUCTION

- Galvanized metal cabinet with powder coated painted surface
- Interior easy to clean per-painted steel
- Adjustable thermostat
- LED lighting
- Glass lids are LowE tempered sliding glass lids with locks and keys standard
- 2" Heavy-duty casters allow easy and fast movement
- Drain plug for easy cleaning
- Lexan sneeze guard
- BDC-12 includes (6) 2- ring tub holds with space for (12) 3 gallon containers, lower level provides extra container storage of (10) 3 gallon containers
- Cold wall refrigeration system, maintains 0° to -10°F

OPTIONS & ACCESSORIES

- Dip Well
- Two ring tub holder
- Graphics

REFRIGERATION SYSTEM

- Refrigeration system uses R290 refrigerant to comply with all environmental concerns
- The unit is best suited for an environment where temperatures remain below 75°F and humidity does not exceed 55%
- Areas with direct sunlight should also be avoided
- Triple access air flow compressor compartment
- Maintenance free condenser



Please verify qualifying units by visiting:
www.energystar.gov/cfs

3779 Champion Blvd., Winston-Salem, NC 27105
1-888-845-9800 Fax: 1-336-245-6453
Beverage-Air.com Sales@bevair.com



BEVERAGE-AIR

Dipping Cabinet Freezer Model: BDC-HC-12

MODEL	BDC-HC-12
EXTERNAL DIMENSIONAL DATA	
Width Overall	68 7/32"
Depth Overall	26 1/16"
Height Overall	52"
Tub Holders	6
INTERNAL DIMENSIONAL DATA	
NET Capacity (cubic ft.)	20.9
Capacity- Top holding area	(12) 3 Gallon tubs
Capacity- Bottom holding area	(10) 3 Gallon tubs
ELECTRICAL DATA	
Full Load Amperes	5.2
Voltage	115/60/1
Nema Plug (8' cord)	5-15P
REFRIGERATION DATA	
Horsepower	1/3+
Capacity (BTU/Hr)	1130
Heat Rejection (BTU/Hr)	1695
Charge (lbs/grams/ounces)	0.22 / 100 / 3.52
WEIGHT DATA	
Gross Weight	307 lbs
Height - Crated	44"
Width - Crated	70"
Depth - Crated	28"

We reserve the right to change specifications and product design without notice. Such revisions do not entitle the buyer to corresponding changes, improvements, additions or replacements for previously purchased equipment. Dimensional tolerances +/- 1/4". Metric dimensions (MM).

Model Views

Required Clearance: 4" Sides & Rear

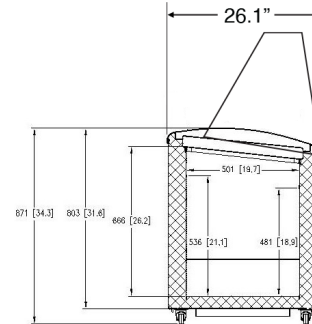

SIDE VIEW

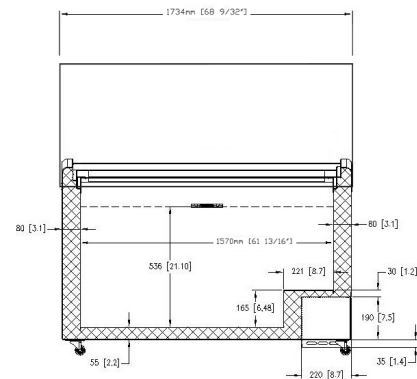

ELEVATION VIEW

ELECTRICAL CONNECTION



115/60/1
NEMA 5-15P

Units pre-wired at factory and include 6.5' long cord and plug set.

