



# AX-CL10M

**Full Size Combi Oven  
Manual Controls - Reversing Fans - 10 Shelves**



		<b>Features</b>
<b>Manual controls</b>	Time, temperature, steam	
<b>Load capacity</b>	10 shelves for full size sheet pans	<ul style="list-style-type: none"> <li>• Advanced airflow design</li> </ul>
<b>High speed reversing fans</b>	3 (3,200 rpm)	<ul style="list-style-type: none"> <li>• Automatic high speed reversing fans</li> </ul>
<b>Space between shelves</b>	3.14" (80 mm)	<ul style="list-style-type: none"> <li>• Manual control: 120 minute timer or continuous ON</li> </ul>
<b>Power requirements</b>	20,000 Watts / 208-240V/60/3 Oven supplied with power cord only / no plug	<ul style="list-style-type: none"> <li>• Interior halogen light</li> <li>• Includes electro valve for direct water connection</li> </ul>
<b>Temperature</b>	86° - 545° F	<ul style="list-style-type: none"> <li>• Adjustable steam percentage (0-100%)</li> </ul>
<b>Equipped with</b>	120 minute timer - signal at end of cycle	<ul style="list-style-type: none"> <li>• Micro safety switch shuts oven off when door is open</li> <li>• Heavy duty stainless steel body construction</li> </ul>
<b>Cavity size (inches)</b>	28.35 x 22.20 x 37.32 (WxDxH)	<ul style="list-style-type: none"> <li>• "Cold Door" design with double pane glass</li> </ul>
<b>Unit dimensions (inches)</b>	38.60 x 33.64 x 49.58 (WxDxH)	<ul style="list-style-type: none"> <li>• Reinforced door hinges</li> </ul>
<b>Shipping dimensions (inches)</b>	41.35 x 40.55 x 52.37 (WxDxH)	<ul style="list-style-type: none"> <li>• Oven cavity is insulated with ultra-high temperature fiberglass insulation</li> </ul>
<b>Net / Ship weight</b>	313 lb / 353 lb	<ul style="list-style-type: none"> <li>• 4 Stainless steel wire shelves</li> <li>• Hand spray for cleaning is included</li> <li>• Ovens can be stacked (kit required)</li> <li>• Warranty: 2 year parts &amp; 1 year labor exclusive of lights, gaskets and glass (60 days)</li> </ul>

## COMBI ACCESSORIES



**AX-C10ST OVEN STAND**

- Heavy duty oven stand with tray support
- Slides accommodate full size pans
- Dimensions: 33.47" x 24.40" x 31.50"
- Heavy duty stainless steel (assembly required)
- Ship weight: 54 lbs
- Shipping dimensions: 38.60" x 28.35" x 8.66"



**R15 CASTERS**

Set of 4 (2 with brakes)



**STACKING KIT**



**HEAVY DUTY DEGREASER RTU**



**COMBI OVEN CLEANER**



**WATER FILTER**

## COMBI OVEN TRAYS

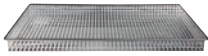

**124-GP31 FRY GRID**



**124-GP32 GRIDDLE GRID**



**124-GP28 GRANITE MULTI-BAKING TRAY**



**124-GP36 MULTIFUNCTIONAL NON STICK ALUMINUM TRAY**



**124-PT12 60X40 ALUMINUM PERFORATED TRAY**



**124-PT13 60X40 ALUMINUM TRAY**

## LINE DRAWINGS

AX-CL10M

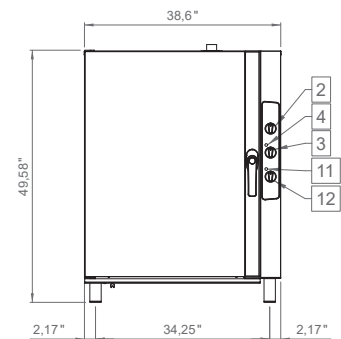
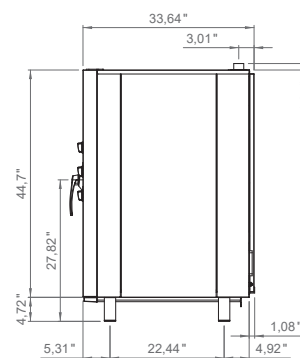
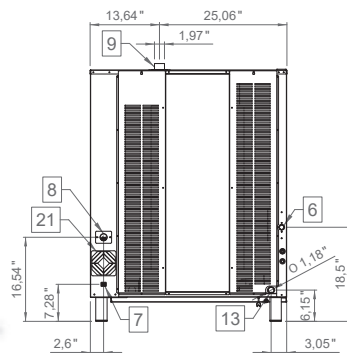

514-737-9701 786-600-4687

TOLL FREE: 888-275-4538

TOLL FREE: 844-218-8477

5659 ROYALMOUNT AVE, MONTREAL, QC, CANADA H4P2P9

12000 BISCAYNE BLVD, SUITE #108, MIAMI, FL, USA 33181

MVPGROUPCORP.COM SALES@MVPGROUPCORP.COM