



# AX-CL06M

**Full Size Combi Oven  
Manual Controls - Reversing Fans - 6 Shelves**



		<b>Features</b>
<b>Manual controls</b>	Time, temperature, steam	<ul style="list-style-type: none"> <li>• Advanced airflow design</li> <li>• Automatic high speed reversing fans</li> <li>• Manual control: 120 minute timer or continuous ON</li> <li>• Interior halogen light</li> <li>• Includes electro valve for direct water connection</li> <li>• Adjustable steam percentage (0-100%)</li> <li>• Micro safety switch shuts oven off when door is open</li> <li>• Heavy duty stainless steel body construction</li> <li>• "Cold Door" design with double pane glass</li> <li>• Reinforced door hinges</li> <li>• Oven cavity is insulated with ultra-high temperature fiberglass insulation</li> <li>• 3 Stainless steel wire shelves</li> <li>• Hand spray for cleaning is included</li> <li>• Ovens can be stacked (kit required)</li> <li>• Warranty: 2 year parts &amp; 1 year labor exclusive of lights, gaskets and glass (60 days)</li> </ul>
<b>Load capacity</b>	6 shelves for full size sheet pans	
<b>High speed reversing fans</b>	2 (3,200 rpm)	
<b>Space between shelves</b>	3.14" (80 mm)	
<b>Power requirements</b>	14,000 Watts / 208-240V/60/3 Oven supplied with power cord only / no plug	
<b>Temperature</b>	86° - 545° F	
<b>Equipped with</b>	120 minute timer Signal at end of cycle	
<b>Cavity size (inches)</b>	28.35 x 22.20 x 24.10 (WxDxH)	
<b>Unit dimensions (inches)</b>	38.60 x 33.64 x 36.35 (WxDxH)	
<b>Shipping dimensions (inches)</b>	41.35 x 40.55 x 39.37 (WxDxH)	
<b>Net / Ship weight</b>	220 lb / 263 lb	

## COMBI ACCESSORIES



**AX-C6ST OVEN STAND**

- Heavy duty oven stand with tray support
- Slides accommodate full size pans
- Dimensions: 23.30" x 20.87" x 31.50"
- Heavy duty stainless steel (assembly required)
- Shipping weight: 50 lbs
- Shipping dimensions: 37.40" x 24.80" x 7.88"



**R15 CASTERS**

Set of 4 (2 with brakes)



**STACKING KIT**



**HEAVY DUTY DEGREASER RTU**



**COMBI OVEN CLEANER**



**WATER FILTER**

## COMBI OVEN TRAYS

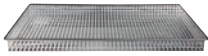

**124-GP31 FRY GRID**



**124-GP32 GRIDDLE GRID**



**124-GP28 GRANITE MULTI-BAKING TRAY**



**124-GP36 MULTIFUNCTIONAL NON STICK ALUMINUM TRAY**



**124-PT12 60X40 ALUMINUM PERFORATED TRAY**



**124-PT13 60X40 ALUMINUM TRAY**

## LINE DRAWINGS

AX-CL06M

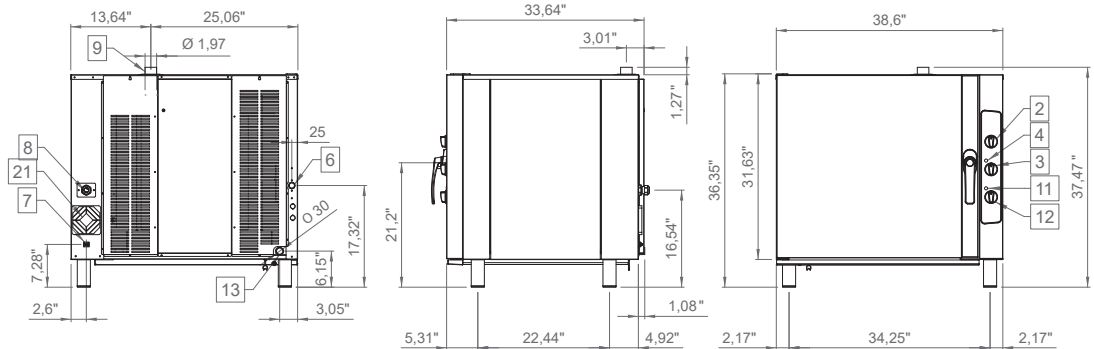

514-737-9701 786-600-4687

TOLL FREE: 888-275-4538

TOLL FREE: 844-218-8477

5659 ROYALMOUNT AVE, MONTREAL, QC, CANADA H4P2P9

12000 BISCAYNE BLVD, SUITE #108, MIAMI, FL, USA 33181

MVPGROUPCORP.COM SALES@MVPGROUPCORP.COM