

## Gas Restaurant Ranges with Oven

36" WIDE



All Stainless-Steel construction, interior and exterior front, and sides. To include **Stainless-Steel grate supports, burner support and pilot tubing**. The all Stainless-Steel construction is designed to last and perform in the most demanding kitchens.

Heavy gauge welded frame on 6" adjustable legs, Stainless-Steel back riser durable enough to hold your broiler without any additional supports. Comes standard with Stainless-Steel cantilever shelf with an optional extended shelf for broiler mounting.

For the safety and convenience of operators, our Asber ranges come standard with a 5" Stainless Steel bull nose landing ledge, Zamac heat resistant knobs for added durability, and reinforced valve system for extra safety. All units are CSA and ANSI certified.

### OPEN BURNER:

- **30.000 BTU** cast iron lift off burners.
- Heavy Duty 12" x 12" cast iron top grates and pilot protection.
- Independent pilot per burner.
- Stainless Steel drip tray.

### GRIDDLES:

- Stainless Steel perimeter top.
- Cold-rolled steel plate 3/4" thick welded to the perimeter top of the truss.
- 4" grease trough channel.

### OVEN:

- Stainless Steel interior with porcelain back door and bottom.
- Removable Stainless-Steel door for easy cleaning.
- Oversized durable Stainless-Steel door handle.
- Thermostatic controlled from 250 °F to 550 °F, CSA and ANSI certified.
- Electronic spark ignition.
- Standard with (1) stainless steel oven rack.
- **Accepts full size sheet pans (18" x 26").**



AEMR-G24-B2-36-H



AER-6-36



AEMR-G12-B4-36

### OPTIONS & ACCESORIES

5" castors.

Additional racks for oven.

Extended overshell for Salamander / Cheesemelter.

Specify LPG or Nat. Gas (comes standard with conversion kits).

Specify is above 2000 ft. elevation.

MODEL	TOTAL BTU PER HOUR	Width	DIMENSIONS Depth	Height	SHIPPING WEIGHT (lbs)
AER-6-36	210.000	36"	33 1/2"	56 1/2"	405
AER-G36-36-H	102.000	36"	33 1/2"	56 1/2"	405
AEMR-G12-B4-36	174.000	36"	33 1/2"	56 1/2"	428
AEMR-G24-B2-36-H	138.000	36"	33 1/2"	56 1/2"	466

1. Height includes 6" legs and backsplash. 2. Specifications are subject to change without prior notice.

# Gas Restaurant Ranges with Oven

36" WIDE

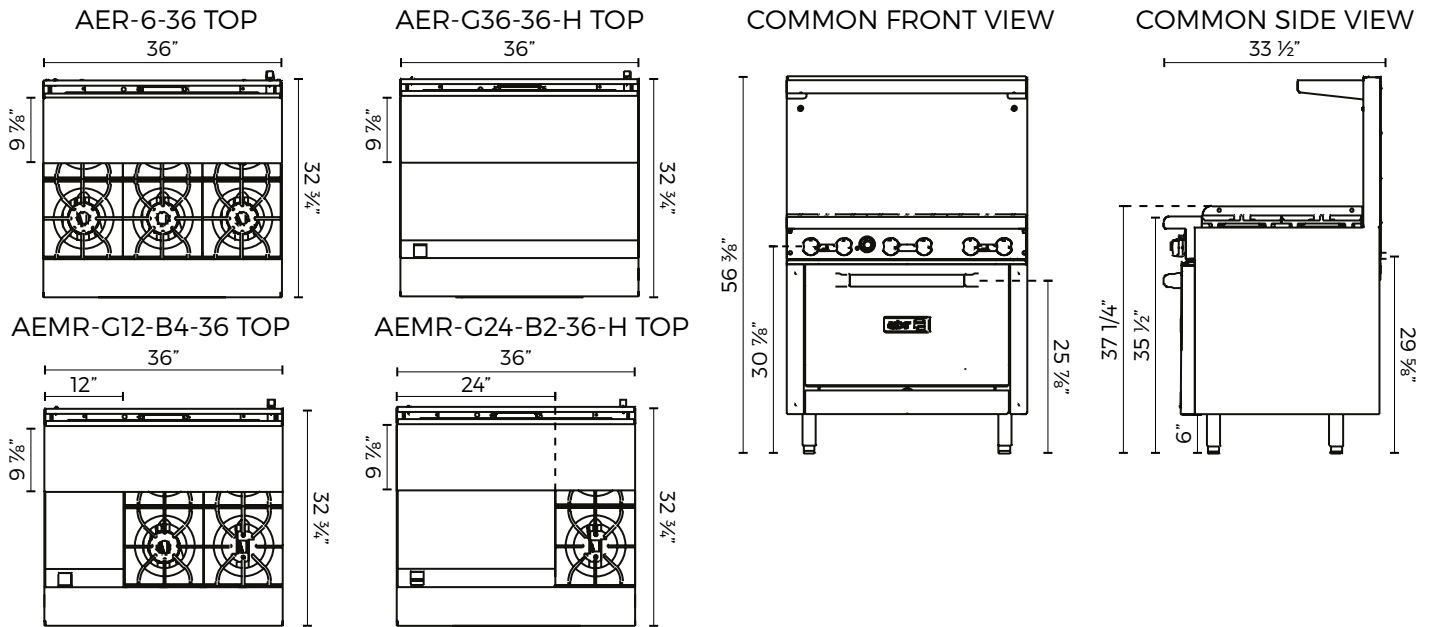

DATA	AER 6-36	AER G36-36-H	AEMR G12-B4-36	AEMR G24-B2-36-H
Gas Type	LPG or Nat. Gas (NG)			
Gas Connection	Gas line: 3/4" or larger			
Regulator	Included			
Gas Pressure	10.0" W.C. (LPG) or 5.0" W.C. (NG)			
Burner BTU	180.000	-	120.000	60.000
Griddle BTU	-	72.000	24.000	48.000
Oven BTU	30.000			
Total BTU	210.000	102.000	174.000	138.000
Shipping Weight (lbs)	405	405	428	466
<b>DIMENSIONAL DATA</b>				
Ext. Width Overall	36"			
Ext. Depth Overall	33 1/2"			
Ext. Height Overall <sup>1</sup>	56 1/2"			
<b>OVEN</b>				
# of Ovens	1			
Interior Length	26 3/4"			
Interior Depth	22 7/8"			
Interior Height	14 1/8"			

1. Height includes 6" legs and backsplash.

### Standard Features

- Gas manifold.
- 6" adjustable legs.
- Independent pilot per burner.
- All units comes either Natural Gas (NG) or LPG Gas. Also includes conversion kits.

### Open Burner

- Heavy Duty 12" x 12" cast iron top grates and pilot protection.
- Stainless Steel drip tray.

### Griddles

- Cold-rolled steel plate 3/4" thick welded to the perimeter top of the truss.
- 4" grease trough channel.

### Oven

- Stainless Steel interior with porcelain back door and bottom.
- Thermostatic controlled from 250° F to 550° F, CSA and ANSI certified.
- Electronic spark ignition.
- Accepts full size sheet pans (18" x 26").

### Options & Accessories

- 5" castors.
- Additional racks for oven.
- Extended overshelf for Salamander / Cheesemelter.
- Specify is above 2000 ft. elevation.

### Warranty

- 1-year parts & labor.
- \*RESIDENTIAL APPLICATIONS: Asber assumes no liability for parts or labor coverage for component failure, factory defect or any other damages for units installed in non-commercial foodservice or residential applications.

## INSTALLATION REQUIREMENTS

- GAS PRESSURE:** 5.0" W.C. (NG) for natural gas or 10.0" W.C. (LPG) for propane gas. A pressure regulator sized for this unit is included, to be installed at time of connection.
- GAS CONNECTION:** Gas line must be 3/4" or larger, same if flexible connectors are used.
- VENTILATION:** An adequate ventilation system is required for commercial cooking equipment. Request more info @ National-Fire Protection Association, www.NFPA.org
- CLEARANCE:** 6" rear & sides for combustible. 0" rear & sides for non-combustible. In the lower part, a space of 4" for all models must be installed with legs of minimum 6".