

AMERICAN RANGE®

A  Company

Project _____

Item # _____

Quantity _____

PASTA COOKER

GAS TYPE: NATURAL LP



ARPC3

STANDARD FEATURES

- All aluminum water tank and heat transfer surface saves energy and speeds up the cooking process.
- Includes (6) baskets.
- 3-ring 80,000/BTU burners create power to quickly bring the water tank to a boil and simmer heat for a gentle boil.
- Heavy-duty welded 12 gallon capacity (14½" x 14½") aluminum tank.
- Integral overflow starch skimmer.
- Built-in tank drain with safety-first locking valve.
- Six perforated 304 stainless steel baskets.
- Limited two year parts and labor warranty.



Model ARPC3
Shown with optional casters



American Range ARPC3 pasta cooker. Aluminum water tank on a 3-ring burner. Unit can be hooked up to a drain for easy draining. Comes with six stainless portion baskets.

The unit is powered with the American Range 3-ring burner firing at 80,000 BTU/hr. During the first stage of cooking, both rings cooperate to bring tank water to a rapid boil – in the second stage of cooking, the inner ring may be used by itself to hold the tank at a gentle boil.



DESIGNED & BUILT IN USA
PROFESSIONAL COOKING EQUIPMENT

A70188 RevC 08042023

AMERICAN RANGE®

A  Company

13592 Desmond St Pacoima CA 91331
T. 818.897.0808 Toll Free: 888.753.9898
www.AmericanRange.com

PASTA COOKER

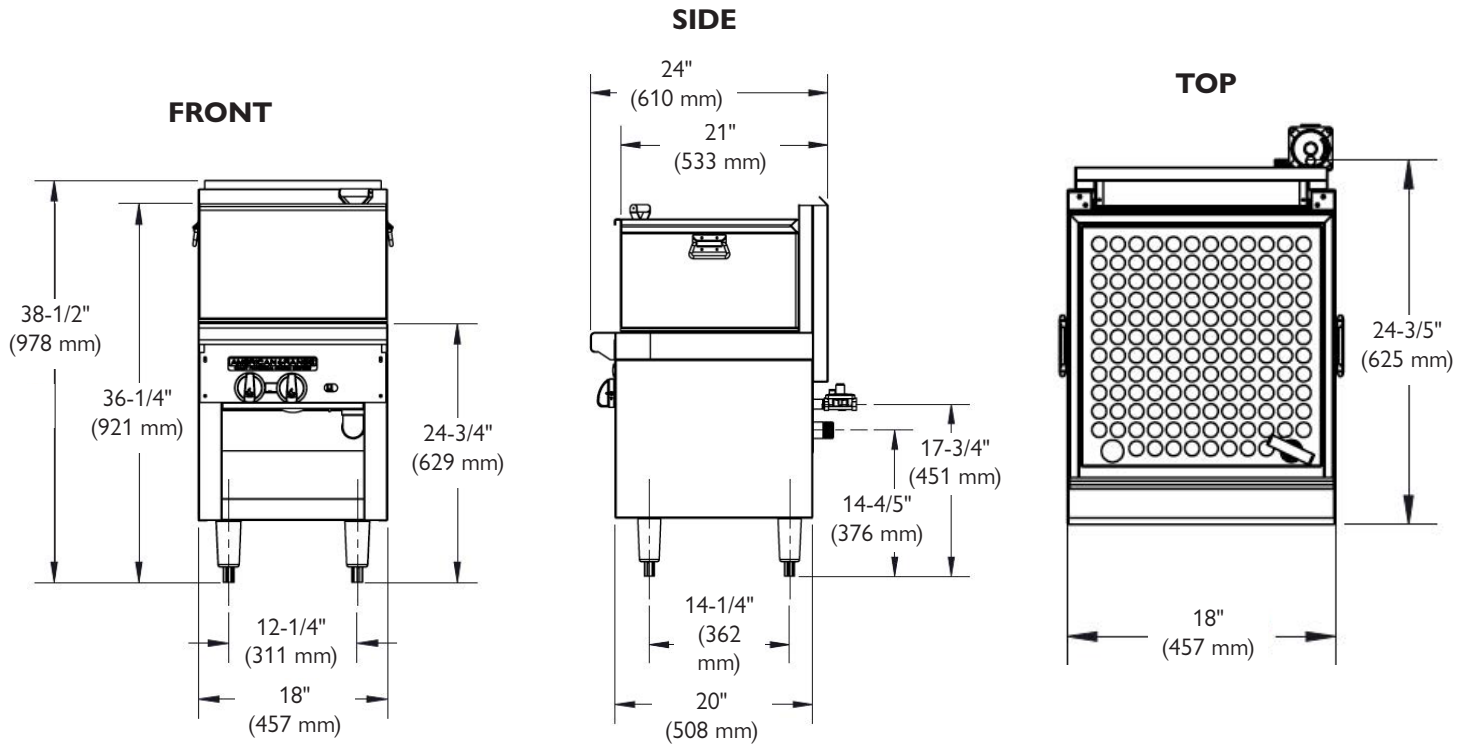

Model	Width	Depth	Height	Burners	Gas Output		Ship Weight	
					BTU	(kW)	Lbs	(kg)
ARPC3	18" (457)	24" (610)	38 1/2" (978)	3-Ring	80,000	(23)	220	(100)

Specify type of gas and altitude if over 2000 feet.

Please specify gas type when ordering.

NMFCCODE: 25970-2 Class: 85

*Shipping weight includes packaging and is approximate.

NATURAL GAS	MANIFOLD PRESSURE	
	PROPANE GAS	MANIFOLD SIZE
5.0" W.C.	10.0" W.C.	3/4" (19MM)

COMBUSTIBLE WALL CLEARANCES:

For use only on non-combustible floors. Legs or casters are required, or 2" (51) overhang is required when curb mounted. Clearance from non-combustible walls is 0". When unit is placed next to combustible walls, clearances must exceed 12" (305) from sides, and 4" (102) from rear. Radiant Broilers for non-combustible locations only.

Commercial cooking equipment requires an adequate ventilation system. For additional information, refer to the National Fire Protection Association's standard.

NFPA96 "Vapor Removal from Cooking Equipment." (NOTE: For North America only)

American Range is a quality manufacturer of commercial cooking equipment. Because of continuing product improvements these specifications are subject to change without prior notice.